

PART
NAME

PLASTIBOX (STYLE A)

PART
No.

PT-11380

MATERIAL: HIGH-IMPACT ABS
COLOR: BLACK OR GRAY
FINISH: TEXTURED BODY WITH
TEXTURED TOP

FOUR (4) #4 x 0.375" LG. SCREWS
SUPPLIED FOR ASSEMBLING TOP.

FOUR (4) NON-SKID PUSH-ON FEET SUPPLIED

NOTE: ALL DIMENSIONS HAVE ±0.015 TOLERANCE
UNLESS OTHERWISE SPECIFIED.

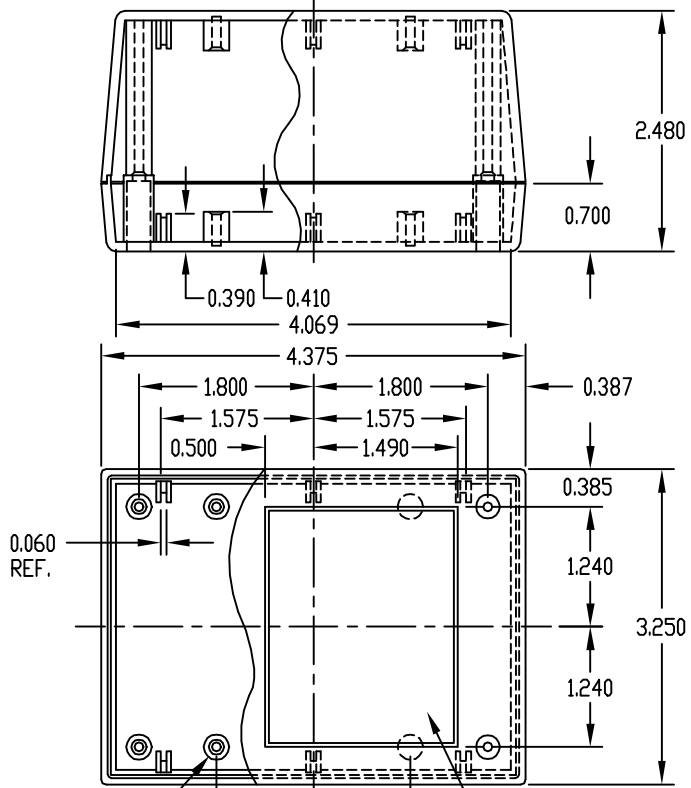
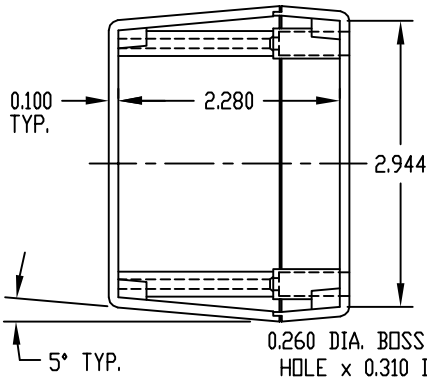

0.260 DIA. BOSS WITH 0.093 DIA.
HOLE x 0.310 DEEP (8) PLACES
MOUNTING BOSSES USE EITHER M2.5 METRIC
OR #4 STD. SHEET METAL SCREWS
x 0.250" LG. (NOT SUPPLIED)

AREA FOR
CUSTOM
MOLDING.

PART
NAME

PLASTIBOX (STYLE A)

PART
No.

PT-11388

MATERIAL: HIGH-IMPACT ABS
COLOR: BLACK OR GRAY
FINISH: TEXTURED BODY WITH
TEXTURED TOP

FOUR (4) #4 x 0.375" LG. SCREWS
SUPPLIED FOR ASSEMBLING TOP.

FOUR (4) NON-SKID PUSH-ON FEET SUPPLIED

NOTE: ALL DIMENSIONS HAVE ±0.015 TOLERANCE
UNLESS OTHERWISE SPECIFIED.

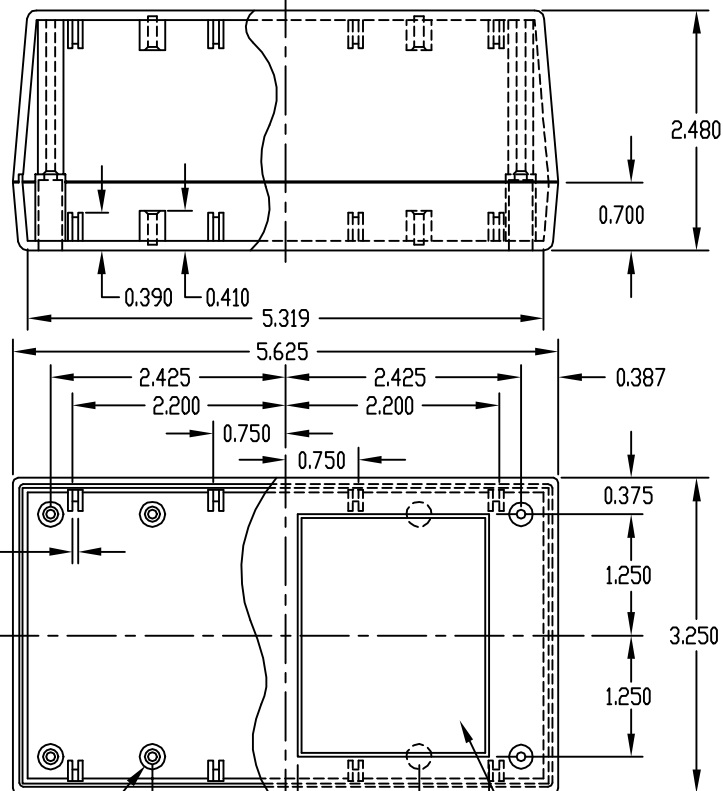
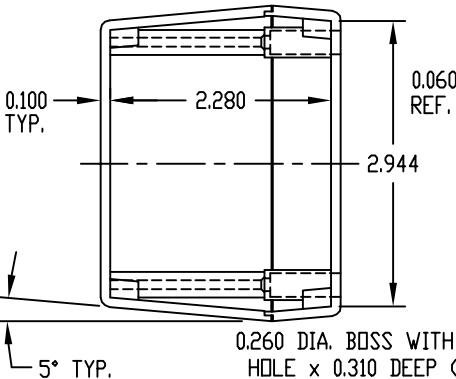

0.260 DIA. BOSS WITH 0.093 DIA.
HOLE x 0.310 DEEP (8) PLACES
MOUNTING BOSSES USE EITHER M2.5 METRIC
OR #4 STD. SHEET METAL SCREWS
x 0.250" LG. (NOT SUPPLIED)

AREA FOR
CUSTOM
MOLDING.